



Canonet



PUB. NO. 5072B
0261 D60
Printed in Japan

Canon

CANON CAMERA COMPANY, INC.
312 Shimo-Maruko-cho, Ohta-ku, Tokyo, Japan
CANON NEW YORK
404 Park Avenue South, New York 16, N.Y.
CANON EUROPE
40 Rue du Stand, Geneva, Switzerland

ELECTRIC EYE CAMERA

1. Flash Unit Connector Socket
2. Photocell
3. Shutter Speed Ring
4. Lens
5. Lens Aperture Ring
6. Distance Scale
7. Shutter Release Button
8. Range-Viewfinder Window
9. Flash Setting Lever
10. Film Speed Indicator Window
11. Accessory Clip
12. Film Plane Mark
13. Cable Release Socket

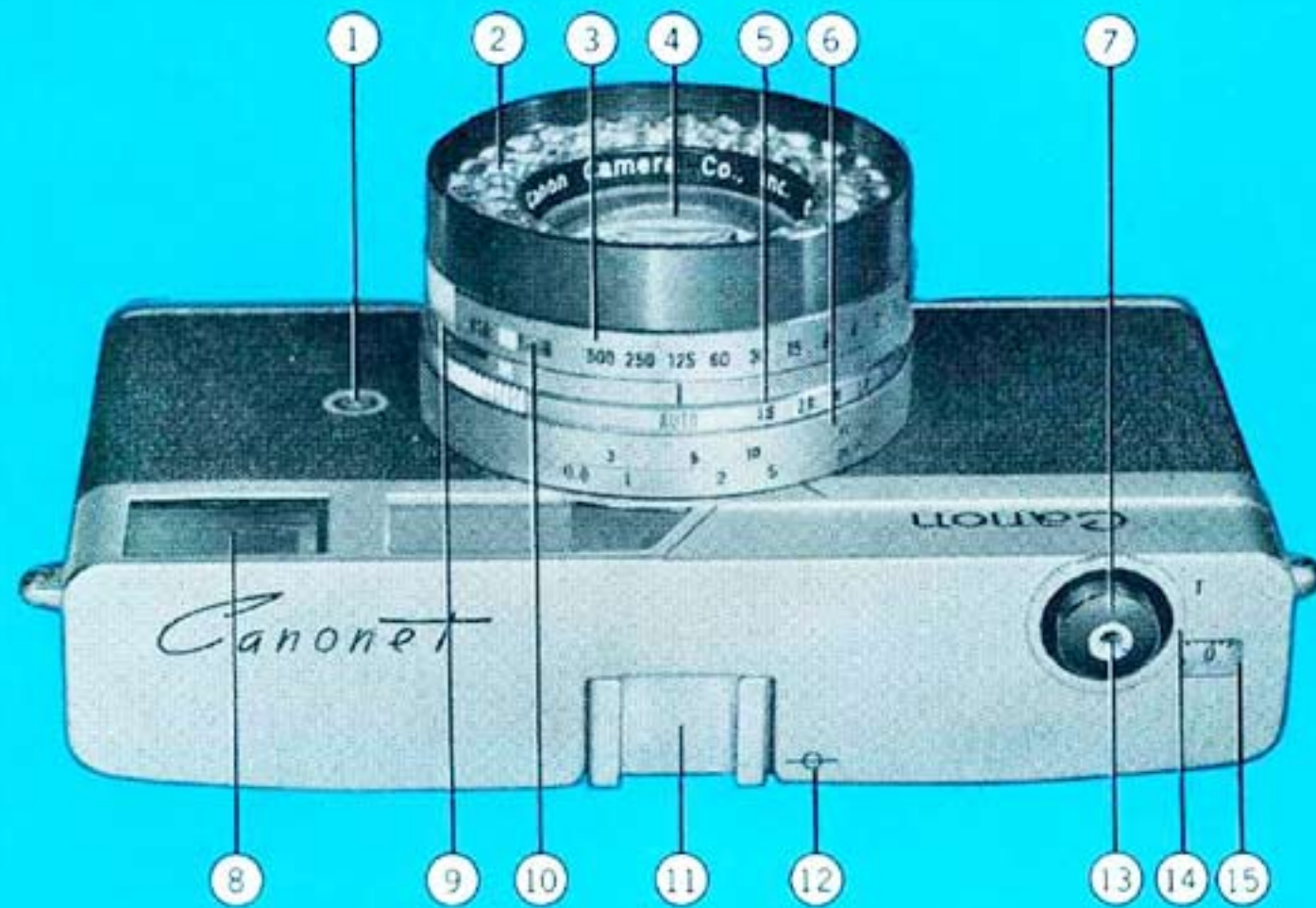

14. Time Ring
15. Exposure Counter Dial
16. Range-Viewfinder Eyepiece
17. Back Cover
18. Trigger-Action Winding Lever
19. Back Cover Opening Button
20. Safety Lock Release Lever
21. Tripod Socket
22. Self-Timer Lever
23. Film Rewind Clutch Lever
24. Film Speed Indicator Lever
25. Focusing Lever
26. Film Rewind Crank

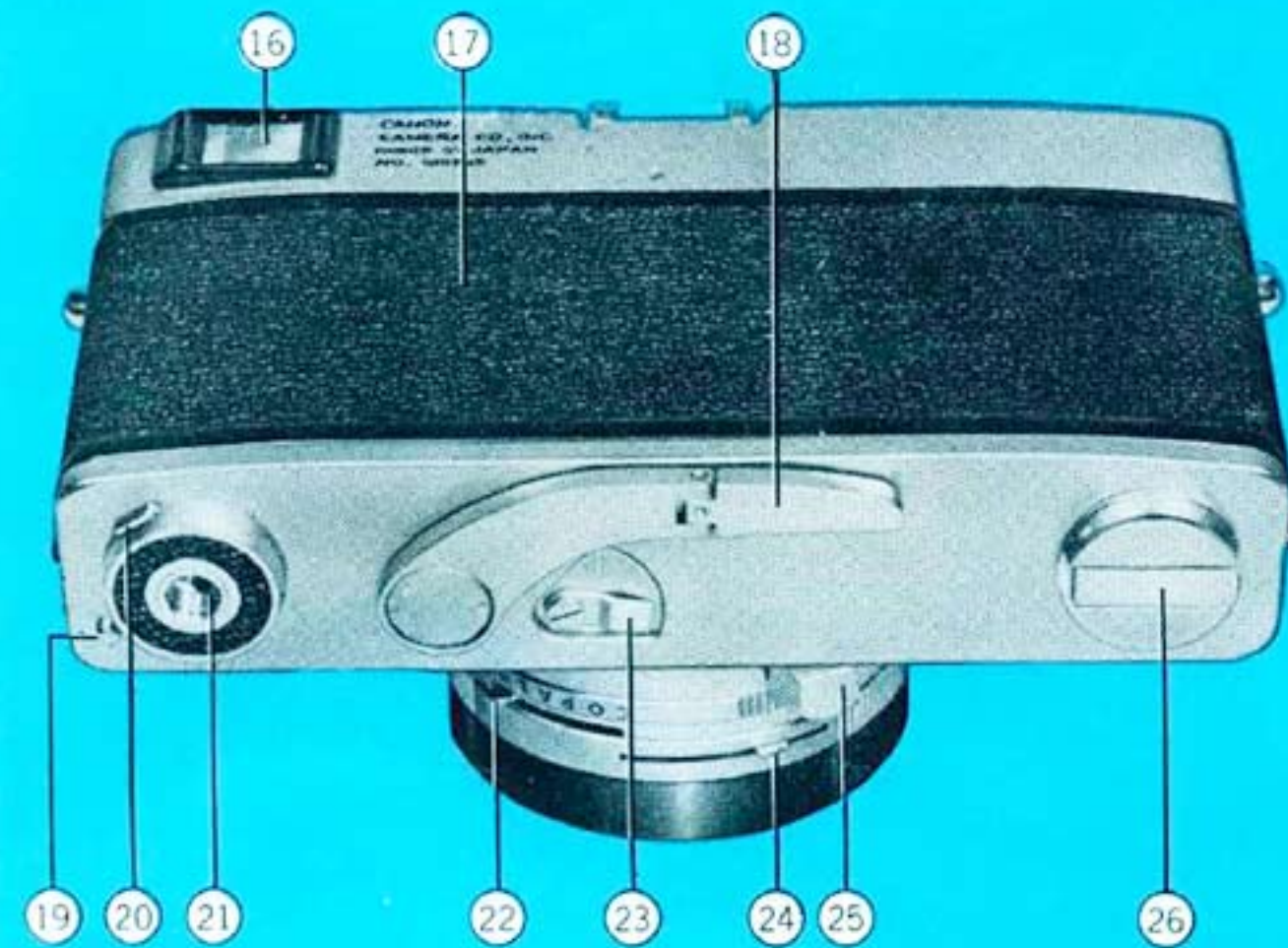

To Prepare for Electric Eye Photography ...

With the Canonet, just about all you have to do is to focus and press the shutter button...

1. Set the lens aperture ring to "AUTO" setting.

2. Set the film speed indicator according to the film used.

3. Set the shutter speed ring. (See chart on opposite page.)

7. Watch the "arrow" mark in the viewfinder. If the "arrow" disappears, the correct exposure is obtained. If the "arrow" pointing to the right appears, turn the shutter ring to the right. If the "arrow" pointing to the left remains, turn the shutter ring to the left. (See page 12 for detailed information.)

4. Wind the trigger lever.

5. Focus and compose.

6. Press the shutter button gently.

Recommended shutter speeds for EE photography

CONDITION	FILM SPEED	ASA 10	16	32	50	100	200
		DIN 11	13	16	18	21	24
 Bright Sun on Light Sand or Snow					1/250	1/500	1/500
 Bright Sun Strong Shadows	1/60	1/60	1/125		1/125	1/250	1/250
 Hazy Sun Weak Shadows							
 Cloudy Bright No Shadows							
 Open Shade under Clear Blue Sky	1/30	1/30	1/60	1/60	1/60	1/60	1/60
 Indoors 100W lamp	—	—	—	—	—	1/8	1/15

There are 6 ASA readings (10 to 200) on the film speed indicator. When using other film speeds--ASA 40 (DIN 17), ASA 64 (DIN 19), ASA 80 (DIN 20), etc.--the film speed indicator can be set between two figures (see illustration).

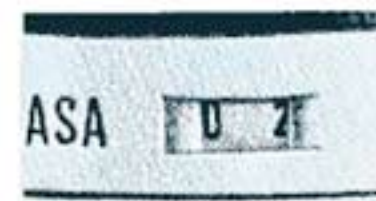

FEATURES OF THE CANONET...

1. Electric Eye Mechanism...

As the shutter button is pressed, the Canon-exclusive Electric Eye mechanism sets the lens aperture for correct exposure according to the light condition of the subject being photographed--then releases the shutter...automatically. No need to figure out correct exposures ever--the Canonet does it for you...automatically. You are assured of perfect pictures...always.

The operating range of the EE mechanism is from LV 5 (F 1.9 with 1/8 sec. or F 5.6 with 1 sec.) to LV 17 (F 16 with 1/500 sec.) using ASA 100 (DIN 21) film, which makes it possible to photograph under almost any normal condition...indoors or outdoors.

The Photocell of the Electric Eye mechanism, arranged around the outer edge of the lens, receives the same amount of light as the lens, which enables it to measure the exact light value. When using a filter, as it covers both the lens and Photocell, it is not necessary to figure out the filter's compensation.

2. Safety Devices...

The Canonet is equipped with various safety devices to prevent mistakes...assuring you of perfect pictures every time. The shutter locks if the lens cap is left on...or the film is not completely wound. Unintentional double exposures cannot occur.

3. Manual Operation...

When photographing beyond the operating range of the Electric Eye mechanism, when using flash, or for special photography, the Canonet can be operated manually as a conventional-type (non-automatic) camera.

Other Features of the Canonet...

Lens:	Canon Lens SE 45 mm F 1.9. Gauss-type 4-group, 5-element construction.
Shutter:	Speeds ranging from 1/500 to 1 sec. in multiple series plus B, T, and self-timer.
Focusing:	Double-image-type rangefinder coupled to the trimming mark finder with automatic parallax compensation.
Film Winding:	Operated by left hand. Trigger-action lever with 95° arc on the base plate.
Film:	Exclusive use of 35 mm film cassette.
Flash Synchronization:	MX flash synchronization. Continental-type flash socket.
Exposure Counter:	Self-resetting type.

Electric Eye Photography ...

With Electric Eye (EE) photography, correct exposure is assured always if these 3 steps are taken:

Canon

- 1 Turn the lens aperture ring and set it at "AUTO" setting.

Index Mark
Lens Aperture Ring

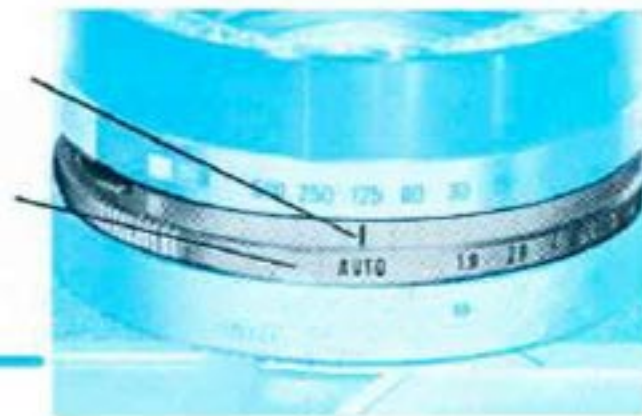

There are "F" stop readings of from 1.9 to 16, in addition to "AUTO," on the lens aperture ring. These "F" stops are used only when the Canonet is operated as a conventional-type camera.

- 2 Turn the film speed indicator lever until the speed of the film used appears in the window.

Film Speed Indicator Window

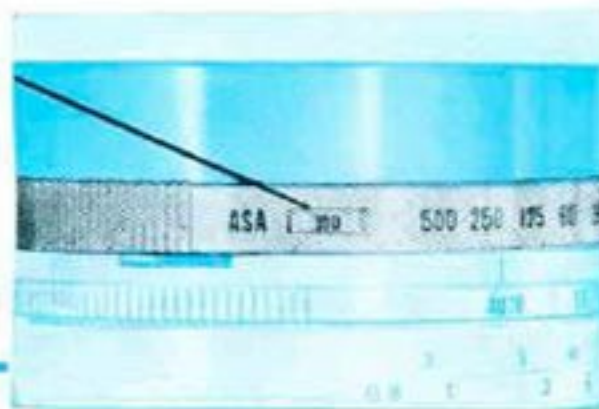

Film Speed Indicator Lever

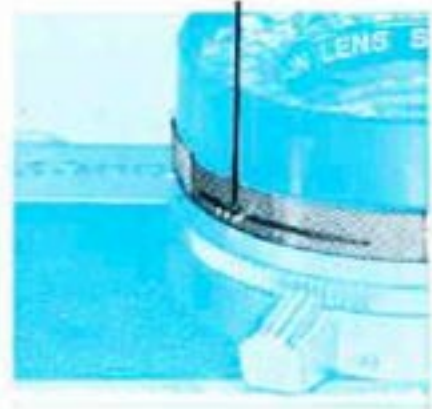

The film speed indicator has 6 ASA readings: 200, 100, 50, 32, 16, 10. See Page 5 for film speeds and comparison between ASA and DIN.

- 3 Turn the shutter speed ring to the desired speed. (See Page 5)

Shutter Speed Ring
Index Mark



The shutter speed ring has fraction readings in 1:2 progression of 500, 250, 125, 60, 30, 15, 8, 4, 2, 1 sec. plus B.
O Do not use the B scale for EE photography. It is not appropriate and may cause damage to the camera.

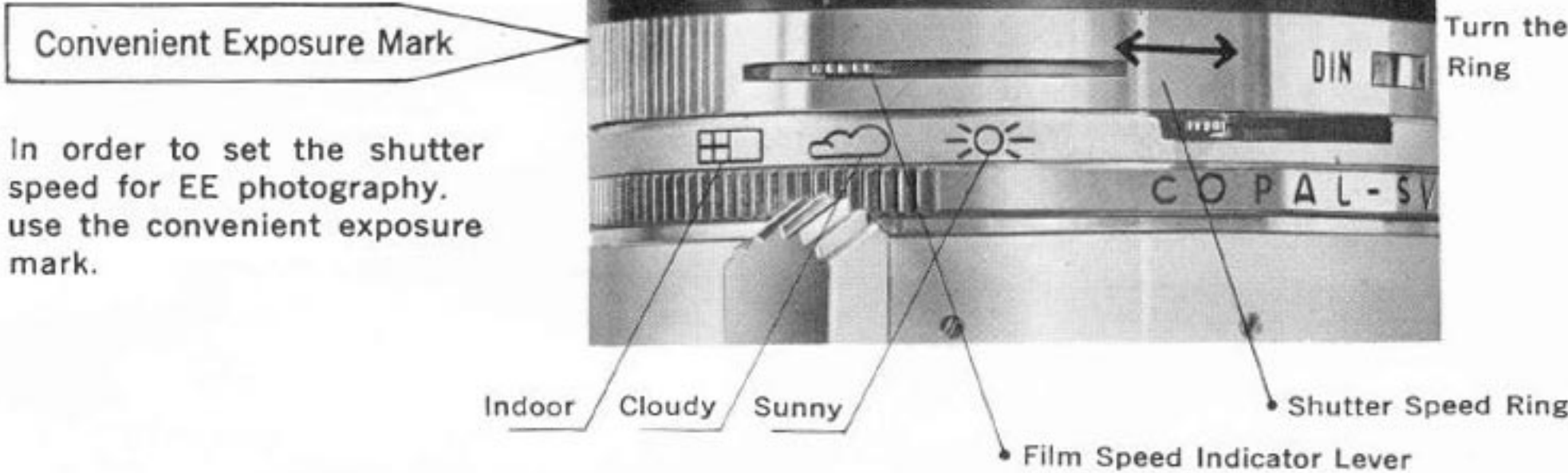

In order to set the shutter speed for EE photography, use the convenient exposure mark.

After the film speed indicator is set according to the film used, turn the shutter speed ring and match the film speed indicator lever with the conditions illustrated indoor, cloudy, or sunny.

It is not necessary to set the lever exactly in the center of the illustration. It can be set anywhere near the center at the point where the shutter ring click-stops. In this case, the shutter speed in use can be read off from the shutter speed dial. There might be a difference of one stop from that shown on the chart on page 5; however, it does not matter.

To set the shutter speed, be sure to turn the shutter speed ring. Do not move or touch the film speed indicator lever.

When the shutter button is pressed, and the EE warning mark indicates incorrect exposure, turn the shutter speed ring accordingly regardless of the exposure mark.

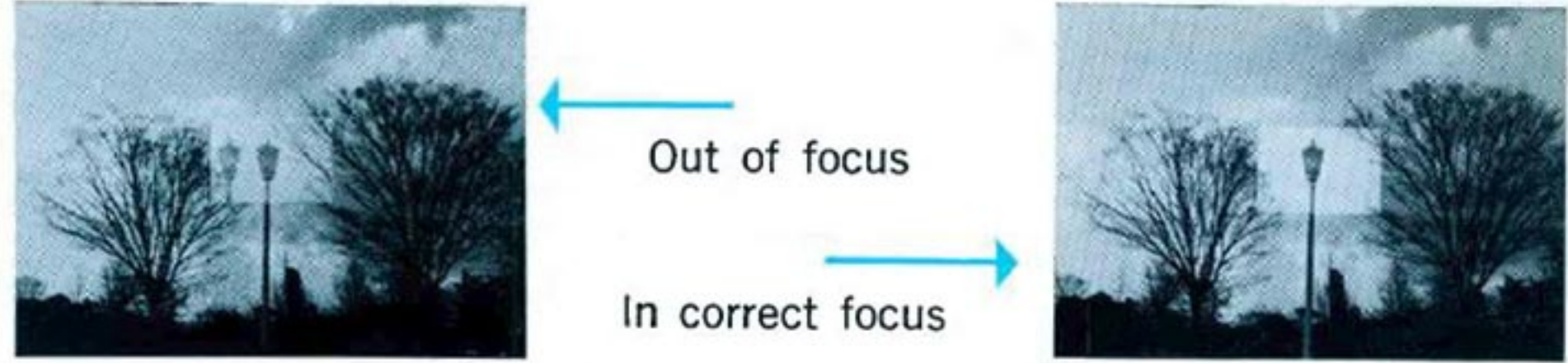

It is not necessary to check the distance scale for normal photography; however, it does tell you the distance between the focused subject and the film. The distance is the point on the distance scale, which is lined up with the black index mark.

Canon

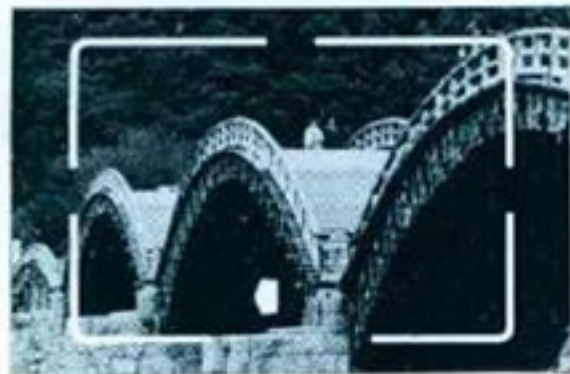

3 Compose your picture . . .

The view seen **WITHIN THE WHITE FRAME** in the viewfinder is that which will be recorded on the film. As you focus on the subject parallax compensation is corrected . . . automatically.

○ An explanation is given on Pages 13 to 15 concerning the "arrow" mark when it is pointing to the left. The "arrow" is seen at the bottom of the viewfinder.



When you cannot release the shutter, follow the directions on Page 14 regarding the "arrow."

4 Now you are ready to press the shutter button . . .

Keeping your eye on the subject through the viewfinder eyepiece, press the shutter button. As the shutter button operates in two stages, it is important that you **PRESS IT GENTLY TO AVOID MOVING THE CAMERA.**

In the first stage, when the shutter button is pressed, the lens aperture is set automatically for correct exposure. In the second stage, the shutter is released.

○ When the shutter button is released, the film can be wound with the trigger lever.

EE "Arrow" Mark . . .

The "arrow" mark in the viewfinder, which always points to the left before the shutter button is depressed, is coupled with the safety devices of the EE mechanism. As you press the shutter button, if the "arrow" mark disappears you are assured of a perfect picture. In case the light condition of your subject is improper for the pre-selected shutter speed, the shutter locks and the "arrow" mark either remains pointing to the left or it points to the right, which indicates the direction in which the shutter speed is to be turned (See pages 14 and 15).

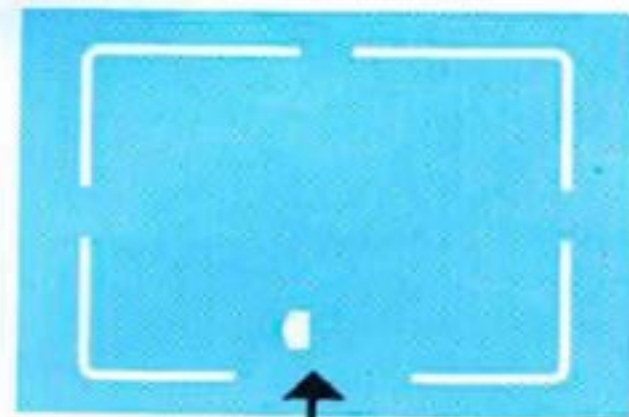

This mark can be seen at all times.



Canon

EE "Arrow" Mark ...

1 With correct exposure :

If the pre-selected shutter speed is correct for your subject, the "arrow" mark disappears when the shutter button is pressed and reappears after the shutter is released.



2 With incorrect exposure :

If the pre-selected shutter speed is not correct for your subject--either the subject is too bright or too dark--the shutter will not be released even if the shutter button is pressed and the "arrow" mark, pointing either to the left or right, remains in the viewfinder. The "arrow" mark is the signal to turn the shutter ring dial in the direction indicated by the "arrow" for correct exposure. If the shutter speed is reset to the correct shutter speed indicated by the "arrow," EE photography can be carried out with the same subject.



If the shutter locks, and the "arrow" pointing to the left remains, turn the shutter speed ring to the left (smaller numbers) for slower speed.



If the shutter locks, and the "arrow" appears pointing to the right, turn the shutter speed ring to the right (larger numbers) for faster speed.



If the subject being photographed is beyond the operating range of the Canonet's exposure meter (EE mechanism)--when the subject is either extremely bright or dark--the "arrow" mark will disappear when the shutter button is pressed, but the shutter button locks at the halfway mark. A picture cannot be taken even if the shutter speed is changed. In this case, EE photography must be suspended and shifted to manual operation.

- When turning the shutter ring, remove your finger from the shutter button.
- The shutter button will not operate unless the trigger lever is wound completely.
- Lens cap must be removed before photographing.
- In case slow shutter speeds such as 1 or 1/2 sec. are used, the shutter button must be kept depressed until the operation of the shutter is completed. If you remove your finger too soon from the shutter button, the diaphragm will return to its maximum opening resulting in incorrect exposure.
- When the background is much brighter than the subject being photographed, or you are shooting against counterlight, there is a strong possibility of insufficient exposure. In such cases change to manual exposure setting, which is described later on.

Self-Timer...

When the self-timer is used, the shutter will be actuated with the maximum delay of about 10 seconds after the shutter button is released. The self-timer is used in this manner:

- 1** Set the flash setting lever to "X"



Flash Setting Lever

- 2** Wind the trigger lever and set the self-timer lever.



Self-Timer Lever

- 3** Turn the time ring of the shutter button to the left so that it points to the letter "T."



- 4** Press the shutter button. Turn the time ring back each time to its former position after the shutter is actuated...otherwise, the trigger lever will be locked and you cannot advance the film.

- Press the shutter button from behind the camera. If you stand in front of the camera to press the button, your shadow will result in incorrect exposure.
- "M" type bulb cannot be used with the self-timer.
- The self-timer can be used for EE photography as well as for photography with manual exposure setting.
- Press the shutter button completely until it locks or incorrect exposure will occur.

Manual Exposure Setting Photography...



If photographic conditions are beyond the operating range of the EE mechanism because the subject is too dark, or you want to do special photography and do not wish to use the EE, remove the lens aperture ring from "AUTO" setting...and set the desired "F" stop for manual operation.

NOTE: For flash photography, manual operation only.

For manual photography...film winding with trigger lever, shutter button, and other operations are same as that for EE photography. The "arrow" mark does not operate for manual photography; so, it is of no concern.

Canon



Manual Exposure Setting Photography...

Bulb and Time Exposures...

"B" Exposure...

The "B" exposure is used for exposures of over 1-second. When the trigger lever is wound after the shutter ring is set to "B," the shutter stays open as long as the shutter button is kept depressed, and closes when your finger is removed from the shutter button.

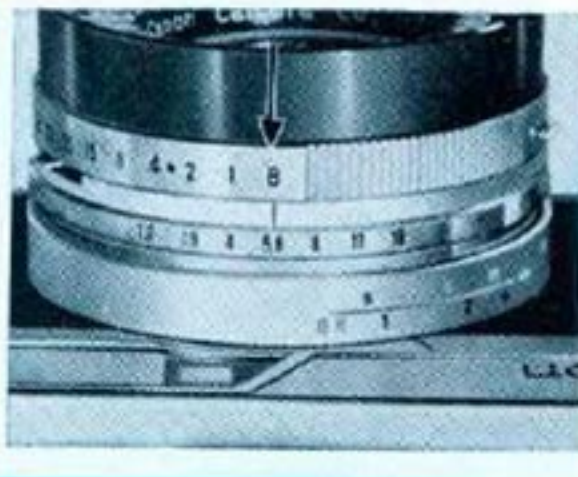

"T" Exposure...

The same method is used for "T" (Time) exposures only the black dot on the time ring is turned to the left (illustrated by the arrow)...set to the letter "T"...and the shutter button is pressed. The shutter button will remain depressed, even after your finger is removed, leaving the shutter open. By turning the time ring to its former position, the shutter button snaps back into its former position and the shutter closes.



Flash Synchronization...

Canonet



Flash Setting Lever

- 1 Attach the flash unit to the accessory clip and insert the cord into the flash unit connector socket.
- 2 "M" type bulb, "F" type bulb, and speedlight can be used. The flash setting lever should be changed to "M" or "X" according to the type of bulb used.

FLASH BULB	SETTING	SHUTTER SPEED
"M" Type Bulb	"M"	All shutter speeds
"F" Type Bulb	"X"	Slower than 1/60th sec.
Speedlight	"X"	All shutter speeds

- 3 For flash photography, the exposure is determined by the guide number; consequently, the aperture ring should be removed from "AUTO" setting.



Film Loading and Unloading...

Film Loading...

The Canonet accepts any standard daylight loading-type 35mm film cassette.

1 To open the back cover of the camera, simultaneously turn the safety lock release lever in the direction of the arrow and press the back cover opening button.

2 Insert the end of the film leader into the take-up spool. Then engage 2 of the perforated holes of the film leader with 2 projections of the film sprocket while rotating the flange of the take-up spool in the direction of the arrow (illustrated).

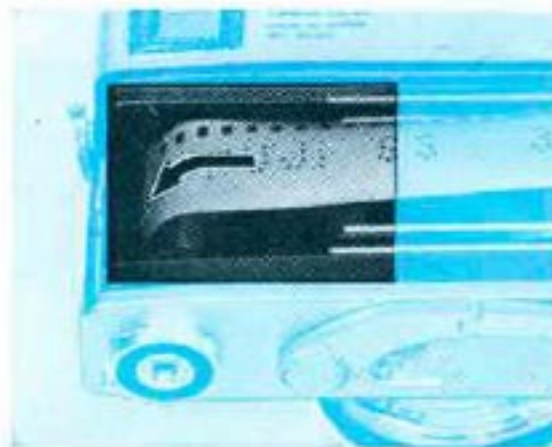
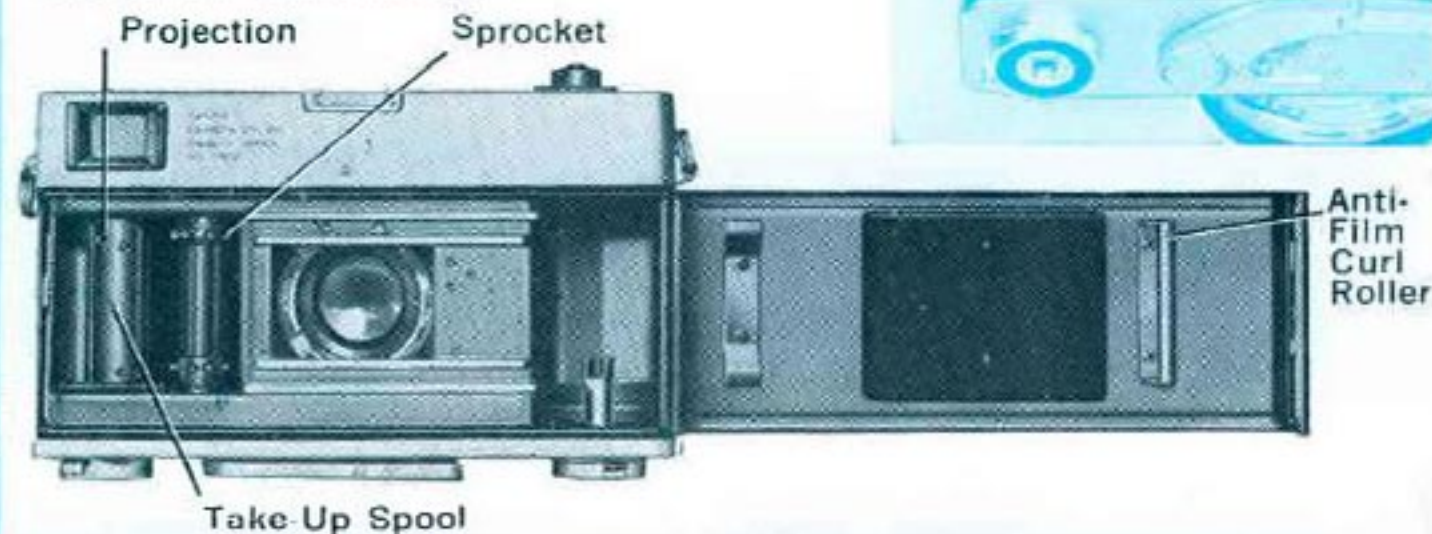

3 Pull out the rewind crank completely and put the film cassette in the recess directly beneath the rewind crank. Then press the rewind crank back to its original position. If there is slack in the film, turn the rewind crank clockwise until the film is taut.

4 Close the back cover, which locks automatically.

5 Remove the aperture ring from "AUTO" setting. Wind the trigger lever and press the shutter button. Keep the lens cap on! Do this twice. Wind the film again. You are now ready for the first shot. Be sure to reset the aperture ring to "AUTO" setting.

○ If the aperture ring is set on "AUTO" setting, the operation of the safety mechanism locks the shutter release button... and you cannot advance the film twice.

○ The film is properly transported if the rewind crank lever rotates when the trigger lever is wound.

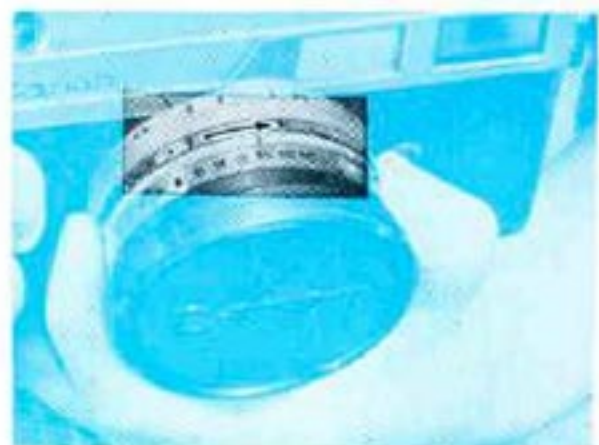

Unloading the Exposed Film ...

When you have used a roll of film and you try to advance the film, you will feel tension on your finger. You should then stop winding and remove the film from the camera in this manner:

- 1 Turn the rewind clutch lever on the base plate to "R."

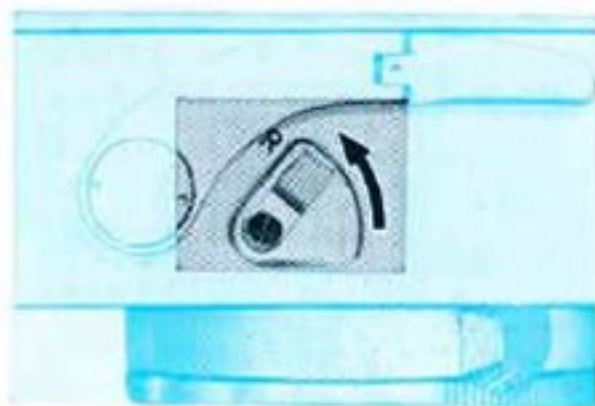

- 2 Raise the rewind crank to its operating position and turn clockwise. Stop winding when the tension on the film-rewind crank suddenly ceases.

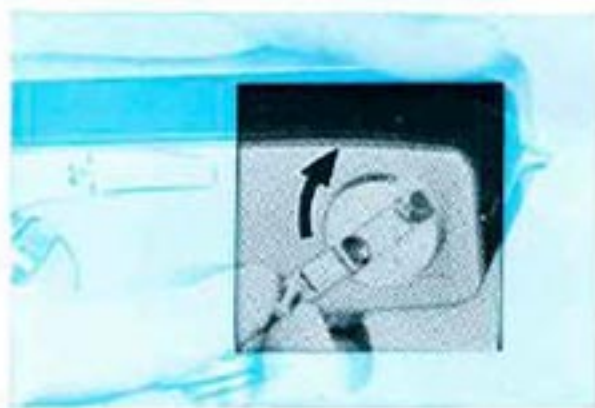

- 3 Open the back cover.



Canonet



- 4 Pull out the rewind crank as far as it will go and take out the film cassette.
 - Be sure to put the lens cap on before rewinding the film.
 - The film rewind clutch lever will return to its original position automatically when the trigger lever is wound; however, it can be done beforehand with your finger tip.

IMPORTANT REMINDER...

- Remove your finger from the shutter button when turning the shutter speed ring or lens aperture ring.
- Do not use "B" scale with "AUTO" for EE Photography. If this is done accidentally (the shutter button locks), follow these instructions:
 1. Remove "AUTO" from the lens aperture ring and set to any other "F" stop.
 2. Press the shutter button (with the lens cap on) and waste one exposure.
 3. Set the lens aperture ring back to "AUTO."
 4. Set the shutter speed ring to desired speed.

Accessories for Canonet...

Clamp-On-Type Lens Hood

The lens hood should be used at all times to eliminate light that is outside the photographic range of the subject. When the Canonet is not being used, the lens hood is put on the lens in the reverse position which enables you to use the lens cap; thus, you do not need a separate case in which to carry the lens hood.



Flash Unit J

Flash Unit J is a convenient, compact, folding-type flash unit, which attaches to the accessory clip. Contains 100 mfd capacitor.



Cable Release

Sturdy all-metal



Tripod

A tripod should be used when using slow shutter speeds to avoid moving the camera.

Eveready Case

The front part of the case can be easily removed by pushing the metal piece upward.



55 mm Screw-In Type Filter

A filter is used for color photography, special effects, lens protection, etc. With the Canonet the filter's compensation is corrected automatically. The Canonet truly takes mathematics out of photography. These filters are available with plastic case; UV, Y1, Y3, O1, R1, G1.

Canon

HANDLING INSTRUCTIONS FOR CANONET

- When you have loaded the film, set the film speed indicator according to the film used.
- Wind the trigger lever completely until it stops.
- Press the shutter button smoothly.
With EE photography, when the shutter button is pressed :
First stage.....the lens aperture is set automatically.
Second stage.....the shutter is released.
- In case slow shutter speeds, such as 1 or 1/2 sec. are used, the shutter button must be kept depressed until the operation of the shutter is completed.
- When using the self-timer with "AUTO." turn the time ring to the left so that it points to the letter "T"
(If you forget to turn the time ring, the lens aperture remains wide open.)
- When using the self-timer with "AUTO." press the shutter button from behind the camera. (If you stand in front of the camera, your shadow will result in incorrect exposure.)
- Do not use flash with "AUTO."

The film speed indicator has 6 ASA readings :
200, 100, 50, 32, 16, 10.

When other film speeds are used the film speed indicator can be set between 2 figures. For example: ASA 160 may be set between ASA 100 and 200 as illustrated.

