

Canon
F-1 SYSTEM

Canon

CONSUMER PRODUCTS GROUP
7230 N. Lindero Avenue Skokie, Illinois 60076 (312) 674-2100

 **BELL & HOWELL**

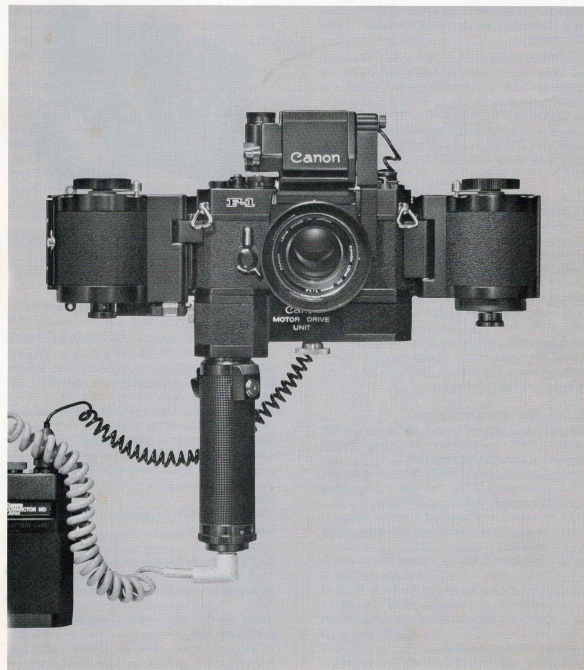

Canon

F-1 SYSTEM

THE SUPREME SLR SYSTEM PROVIDES A NEW DIMENSION IN PROFESSIONAL PHOTOGRAPHY

Canon takes pride in introducing the world's finest single-lens reflex camera featuring the highest performance. It is called the Canon F-1. It is high-precision camera that extends photographic techniques to the highest levels in specialized fields.

Canon's integrated technology, that has supplied the world with numerous kinds of high-grade precision cameras, was concentrated in the development of the revolutionary F-1 system.

1. Extensive System with Top Quality and Durability

The most outstanding feature of the F-1 is that it possesses an extensive system which includes a great durability sustain the functioning of this magnificent system. The Canon F-1 system was completed only after it was checked from all angles, including performance, accuracy, durability, interchangeability, manipulation, design, production and quality control.

Components that make up the F-1 system number over 10,000. The average number of components in a quality camera is approximately 1,000. This means the F-1 is a truly epoch-making camera system.

2. Body Mechanisms and System

Centered around high performance, high quality and high reliability, the F-1 is a wide-range system camera that was developed to achieve the following goals:

1. Complete interchangeability with all accessories.
2. Development of high performance accessories by the adoption of electronics techniques.
3. Integrated development of a series of top-quality lenses and special lenses with the use of electronic computers.
4. Guaranteed quality for any kind of photographic system. The F-1 system, which was developed to attain these goals, can be adapted to almost all accessories of the Canon FT QL system for systematic use according to photographic purposes.

Systems are classified as follows:

1. Lens system centered around the high-performance FD lens group.



2. Viewfinder system in which pentagonal prisms are interchangeable.
3. Continuous shooting system centered around the motor drive.
4. Canon Auto Tuning (CAT) System centered around a high-grade electronic flash unit.
5. Close-up photographic system.
6. Photomicrography and copy system.
7. Power system.

It is a masterpiece in itself. It can perform everything that a conventional SLR camera can do: ordinary photography, oscilloscope photography, copy photography, close-up photography, macrophotography, photomicrography, and astronomical photography.

Moreover, unmanned automatic photography is now possible with the combined use of the Servo EE Finder and Motor Drive Unit. Timer-coupled photography under insufficient lighting conditions can be performed with the use of the Booster T Finder. Automatic flash photography is also possible by using a new electronic flash unit Speedlite 500A.

These features make the Canon F-1 an unprecedented system camera.

3. Wider Range of Interchangeable Lenses

The F-1 has enlarged the range of high-performance lenses in the super-wide-angle, super-telephoto and standard lens fields.

As with the body, strict conditions for higher performances in the lenses were satisfactorily met from the standpoints of accuracy, resolving power and aberration correction. Rare-earth glass is used with the maximum effect and new mechanisms are incorporated to perform close-distance

compensation.

A new series of lenses from 7.5mm to 1200mm has been added to increase the number of interchangeable lenses. (At first, there were eight FD lenses.)

4. Guaranteed Quality

Quality underlines performance. Basic studies, such as material analysis before designing were started and scrutiny of processing methods fully carried out. Materials used were closely examined for quality, and high-grade materials were abundantly used. A special standard even more severe than the already strict Canon Standard is adopted to guarantee top quality. In the field of production, processing accuracy, assembly accuracy and adjustment accuracy are secured at a level one grade higher—to the point of micron orders. Production control is performed by electronic computer for systematic distribution, control, assembly, inspection and delivery of components to secure the highest quality.

5. Super-Durability

The various mechanical components have been strengthened in durability on an average of two to three times so that they would withstand the most rigorous use. Moreover, the components have been rationally designed. Thus, the components are guaranteed to pass the most rigid durability test with flying colors. Environmental testing included vibration, shock and operational tests for extended periods in temperatures between 60°C (140°F) and -30°C (-22°F). The durability test was conducted with the camera body alone and also together with the Motor Drive Unit for 100,000 exposures. These standards are very high for any camera.

6. Wider Range of Applications

The F-1 is an all-round system camera designed for a wide range of uses such as news gathering, scientific research, measuring, commercial photography, artistic use and for preserving documents on film.

Over 180 complete accessory groups, such as the Servo EE Finder and Motor Drive Unit, were developed.

A TTL full-aperture metering system was developed in which a wide-range and highly sensitive light-receiving element was positioned on the focal plane.

Together with improvements in component accuracy, the high-speed shutter screen, incorporating a perfect brake

system, was developed for 1/2000 second ultra-high shutter speed, greatly increasing the camera performance for shooting moving subjects.

- Shutter priority time EE photography is possible with the use of the Servo EE Finder.
- Metering under insufficient light conditions down to EV-3.5 and long-time exposures with the automatic timer coupled to the shutter release button are possible with the use of the Booster T Finder.
- Changing of shooting intervals between three frames per second and one frame per 60 seconds is possible in timer photography with the use of the Motor Drive Unit.
- Long-length roll film photography is possible with the combined use of the Motor Drive Unit and Film Chamber 250.
- Unmanned photography is possible with the combined use of the Motor Drive Unit and Servo EE Finder. Combined remote-controlled and long-length roll film photography is also possible.
- Viewfinders including Eye-Level Finder, Servo EE Finder, Booster T Finder, Speed Finder and Waist-Level Finder are interchangeable.
- In addition to the stabilization of the film plane with the large size pressure plate and cassette stabilizer, improvements were made for film plane stabilization even when the film is left untouched for long periods of time.

The matching-needle-type automatic flash control system, CAT System, was adopted using a designated lens and the Speedlite 500A.

Stopped-down metering with lenses other than the FD type is possible. Moreover, meter readings are indicated inside the viewfinder.

Analytical research produced noise-proof mechanisms for the various functioning sections.

As a result of research into high speed photography, the movements of the various functioning mechanical sections, such as the mirror and shutter, were rationally designed for optimum operational efficiency.

Moreover, the various parts of the camera body were made completely airtight to seal in the movement noises.

Four kinds of focusing screens, all interchangeable, are available for use inside the viewfinder.

Boasts modern exterior design in line with the entire system and also easy-to-use features from the standpoint of human engineering.

Universal Light Metering System

— Full aperture opening, stopped-down metering, EE, insufficient light volume, unmanned automatic photography —

Many signal transmitting mechanisms for an interchangeable-type single-lens reflex camera are built into this metering system to the maximum extent. It has a very versatile TTL system metering mechanism correlated to the development of the FD series of lenses and accessories. It can be commonly used for full-aperture metering and stopped-down metering. In the case of lenses other than FD lenses, stopped-down metering can be performed.

Meter readings are indicated inside the viewfinder, which does not become dark even during stopped-down metering. In the case of the Servo EE Finder, Electric Eye operation with shutter priority is possible by means of full aperture metering.

When the Motor Drive Unit is used jointly with this, unmanned EE photography can be performed. Moreover, photography with long-length roll film becomes possible with the attachment of a Film Chamber 250.

When the Booster T Finder is attached and the aperture is stopped down, insufficient light volumes of EV-3.5 can be metered, and long-time exposures can be achieved by the built-in timer.

A. Perfect TTL Metering System

The metering system of the F-1 begins where the already established highly accurate focal point metering system of the FT left off. In terms of both accuracy and theory it was developed into an almost perfect full-aperture metering system in combination with FD lenses and special wide-range, high-performance CdS photocells.

Moreover, in the case of FL lenses and R lenses, the same high level of exposure accuracy is possible by stopped-down metering.

By focal point metering is meant the metering, under actual photographing conditions, of the best quality light beam of the focal plane at the closest position possible.

It is the ideal system for immediately metering the condition of the subject at the focal plane. It assures accurate automatic metering even if the f /numbers of interchangeable lenses change, so that it is not necessary to adjust the setting of the f /number manually.

- High illumination at photometry plane and large meter

current.

- In order to increase the range of full aperture metering for the F-1, Canon developed a CdS light meter element with a high resistance electrode having a highly accurate illumination resistance curve in which the high and low illumination sensitivity distribution is uniform. This has eliminated unstableness in metering, usually evident in conventional CdS light meters, and guarantees the accuracy of the F-1.

Metering error is negligible due to ideal distribution of light.

With this focal point metering system as the basis, the F-1 adopted the exposure setting mechanism and error correction mechanism of the camera body and lens sides as signals and incorporated the optimum full-aperture metering system.

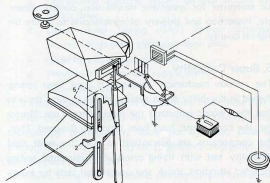

1. CdS
2. Aperture Signal Coupling Lever
3. Aperture Needle
4. Meter Needle
5. Beam-Splitting Mirror

- **Bright and Easy to Look Through**

The angle and pitches of micropriam were decided by based on nature of human eyes.

The reflecting ratio of the beam-splitting mirror in the condenser has been reduced to 45% of that for the FT model and the light transmitting rate of the taking lens has been increased through the development of highly sensitive CdS photocell.

- **Meter Reading Information**

All the necessary information of the meter readings are readable through the detachable finder. A small pentagonal prism is fixed to a side of the pentaprism so that light is led through the light taking window situated on the top of the camera body.

B. Viewfinder System

The viewfinder of the F-1 is of the interchangeable type. As a viewfinder for a single-lens reflex camera, it has a most thoroughly scrutinized system.

The following five interchangeable viewfinders are available for use according to purpose. These are the Servo EE Finder, Booster T Finder, Eye-Level Finder, Speed Finder, and Waist-Level Finder. The F-1 comes with the Eye-Level Finder attached.

The viewfinder is easily detachable. It can be removed by pulling towards the rear while pressing the release buttons on the sides. When mounting the viewfinder, insert it from the rear along the rails on the upper part of the mirror box. It becomes locked when pushed all the way in.

The focusing screen is also interchangeable. The standard microprism screen, the same as that in the FT, is used. Three types, including split-image, all-mat, and section type, are available for use according to purpose.

The focusing screen is attached with a condenser and is built into the entire frame. It has a beam-splitting mirror for directing light to the CdS.

The focusing screen can be easily removed by inserting your fingernails into the two notches on the rear end and pushing upwards. When attaching the focusing screen, insert the forward claw under the stopper of the mirror box and then drop in the entire focusing screen horizontally. The Angle Finder B, Magnifier, Dioptic Adjustment Lens, and Eyecup can be attached to the eyepiece.

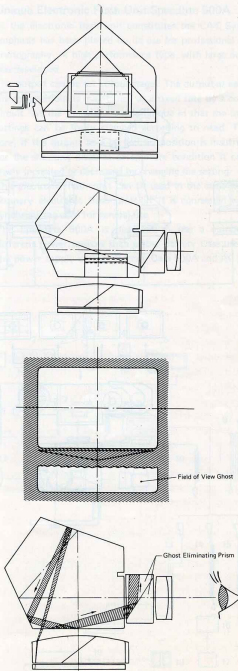

C. Meter Information

Focusing-screen readings and meter readings can be observed inside the viewfinder. The meter reading mechanism includes: meter needle and aperture needle, improper exposure warning marks, stopped-down metering/battery check mark, shutter speed scale, and meter coupling out-of-range warning.

- **Ghosts Elimination**

By installing two prisms between the pentaprism and the eyepiece lens, total-reflection and clear visibility were enabled. Ghost effect which otherwise would appear in the lower part of the viewfinder was eliminated.

The shape of the pentaprism's rear surface has been designed to reduce ghosts peculiar to the pentaprism.

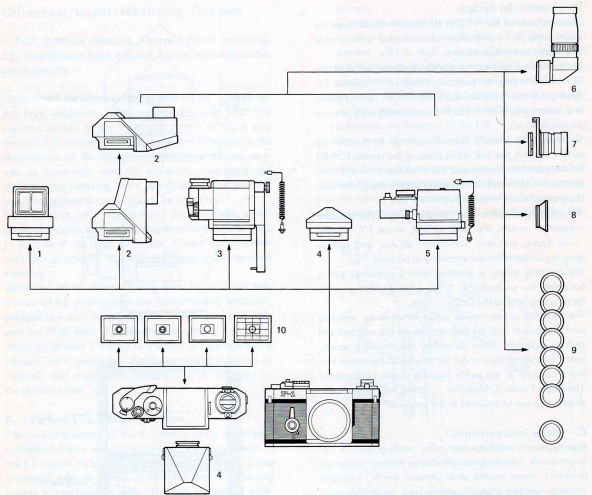

1. Waist-Level Finder
2. Speed Finder
3. Servo EE Finder
4. Eye-Level Finder
5. Booster T Finder
6. Angle Finder B
7. Magnifier
8. Eyecup
9. Dioptric Adjustment Lenses
10. Focusing Screens

CAT System - Matching-Needle-Type Automatic Flash Mechanism

Synchronized flash photography has now become an everyday affair with the rapid progress and popularization of the electronic flash unit and the development of smaller flash bulbs.

Previously, in synchronized flash photography it has been necessary to set the proper f/stop after tiresome calculation. In this case, the guide number is used as the basis and the f/stop is obtained according to the shooting distance. Recently, however, the development of the automatic flash mechanism makes coupled-to-flash photography possible with lens-shutter cameras.

Canon developed a more sophisticated device in which the EE has been incorporated into the electronic flash unit, adopted in the New Canonet marketed in 1969. This design policy was incorporated in the F-1. An automatic flash control mechanism was built in so that proper f/numbers can be determined by the matching needle method using a newly developed the Speedlite 500A and a prescribed lens. Thus, synchronized flash photography is now possible with the same ease as metering manipulations.

Unique Electronic Flash Unit Speedlite 500A

In the electronic flash unit constitutes the CAT System, emphasis has been placed on its use for professional news photography. A high performance type, with large output was developed.

The output can be set at four stages. The output at each of the set positions is maintained at a fixed rate by a control circuit. At the same time, it is unique in that the output settings can be freely changed according to need. Therefore, if the output at a certain set position is insufficient for the shooting distance or aperture condition it can be freely increased or decreased by changing the setting.

This electronic flash unit can be used in the same way as ordinary electronic flash units, if it is connected with a synchronizing cord for general use.

The Speedlite 500A is designed to use a number of different power sources such as the Battery Case used for the power supply system, Battery Case 500A and AC pack.

1. Flash J-3
2. Flash Quint
3. Flash V-3
4. Cube Flash, Cube Flash D
5. Speedlite 102
6. Flash Coupler D
7. Flash Coupler
8. Speedlite 500A
9. Extension Cord 500A
10. Cord 500A
11. Flash Adapter
12. Bracket
13. AC Pack
14. Cord 12V 3S
15. Battery Case 500A
16. Battery Case
17. Battery Magazine 12V
18. NiCd 500FZ
19. NiCd Charger 500FZ

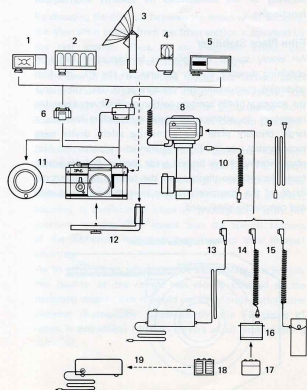

1/2000 Second Shutter Speed Available — Durable for 100,000 Exposures.

The shutter mechanism of the F-1 is one of Canon's proudest technical achievements.

Functionally, this shutter mechanism is outstanding because of its extremely fast 1/2000 second shutter speed, greater exposure accuracy due to increased shutter screen speed, and increased durability with the use of a metallic shutter screen. More remarkable is the fact that Canon has produced a shutter mechanism of matchless quality, durable for 100,000 accurate exposures at the very difficult high speed of 1/2000 second. The fast shutter speed of 1/2000 second now makes possible the habitual use of high speed film and will also prove extremely effective in such high speed photography as shooting sports events. Furthermore, it is possible to speed up the X contact to 1/60 second due to the improved screen speed.

Materially, special alloy and ball bearings are used in the bearing section and special oil is injected to guarantee accuracy of the components for stability and smooth functioning.

Film Plane Stabilizer

An evenly spaced film plane is an important factor in obtaining superior quality pictures. In the FT, the film advancing mechanism; the pressure plate, the roller, and the accuracy of the aperture section received very favorable reception. In addition to these outstanding features, a larger pressure plate and a cassette safety device were incorporated into the F-1 to guarantee a superior flat film plane worthy of this highest grade camera. Defects arising from the rotation direction of the take-up spool and the depth of the magazine chamber were thoroughly studied and completely eliminated.

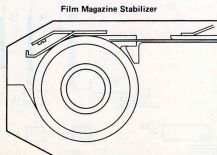

The cassette stabilizer eliminates the peculiarities of different films arising from the difference in height between the cassette and the rail surface, and together with film holder roller is very effective in stabilizing the film plane. Furthermore, in adopting the large-size pressure plate, scrupulous care was taken regarding related mechanisms, such as making windups lighter. Thus, the performances of the interchangeable lenses can be given full play.

Interchangeable Lens Group System

The full-aperture metering system has been adopted for the F-1. This system boasts an accuracy equal to, if not better than, the stopped-down metering system and includes a transmitting mechanism for transmitting aperture signals to the lens and camera body. In order to expand the F-1 system Canon has developed a series of high-performance interchangeable lenses of the highest quality. Together with special lenses, they have realized a wide variation of lenses.

A. Designed for Wide-Range, All-Round Application

1. Perfect Aspherical Standard Lens

The FD 55mm F1.2 AL is a perfect lens that assures the highest grade delineation power under all photographic conditions, including ordinary daylight photographic conditions, fully open aperture conditions at night, close-distance photography, and close-up photography. Despite the fact that it has a large aperture of F1.2, this lens has extremely little flare and images of very high contrast are attainable, even at full aperture opening in night photography, because the lens uses an aspheric optical surface. Furthermore, this lens has been specially designed to minimize the decrease in resolving power at small apertures which is common to conventional aspherical lenses.

A Full Range Aberration Free System, which changes the distance between lenses was utilized in order to eliminate breakdowns completely in aberration from infinity to close distance, and this has contributed to stabilized image delineation.

In order to increase the degree of contrast of images and to eliminate flares completely, this lens is treated with Canon's unique Super Spectra Coating. This contributes to a 40 percent decrease in surface reflections compared to conventional lenses.

Based on the above features, this lens can be evaluated as a very high quality lens from all angles.

2. Wide-Angle and Telephoto Series of Lenses

The world's shortest wide-angle lens for single-lens reflex camera use with no curvature aberration, the FD 17mm F4, was newly developed together with the FD 24mm F2.8 and FD 35mm F2. With the development of these three lenses, a wide-angle series of lenses from 63° to 103° of view, at approximately 10 degree intervals, has been completed. On the telephoto side, a series of lenses at 100mm intervals in focal length are now available. Starting from the FD 100mm F2.8, FD 135mm F2.5, FD 200mm F4 and FD 300mm F5.6 group of basic telephoto lenses, going through the front-component interchangeable type compact FL 400mm F5.6, FL 600mm F5.6 and FL 800mm F8 lenses, the series ends with the newly designed FL 1200mm F11.

3. Development of a FL-F Series of Lenses

The FL-F 1000mm F11 was newly added to the FL-F 300mm F5.6 and 500mm F5.6 series of lenses using artificial fluorite, greatly strengthening the applicability of this series of small size, high-performance telephoto lenses. The FL-F 1000mm F11 has a very short over-all length of 586mm compared to its focal length, and is a compact lens, approximately the size of an ordinary 600mm lens. The contribution of fluorite use is that it completely corrects chromatic aberration. It makes elimination of the secondary aberration easy and also makes the telephoto ratio small. The FL-F 1000mm F11 embraces all these features. Canon's high level of technology was acknowledged throughout the world when its conventional FL-F lens was awarded the 1969 Extraordinary Diploma of Honor by Interkamera in Hamburg.

4. New Developments in Aspherical Lenses

As a second stage development in aspherical lenses, the TS 35mm F2.8 AL, which can tilt and shift, has been developed.

Succeeding the wide-angle techniques which improved the contrast of large aperture lenses at full aperture by the use of aspheric optical surfaces, it was discovered, as result of research, that the aspheric optical surfaces were also effective in decreasing hitherto unavoidable flares outside the optical axis in retro-focus type wide-angle lenses. This discovery was applied in the TS 35mm F2.8 AL which requires a specially large wide angle.

Perspective correction can be made with this lens. At the same time, depth of field can be controlled by tilting the

lens. It is a lens with a large image circle, so that it can be used up to angles of view comparable to those of a 28mm wide-angle lens, although its focal length is 35mm.

5. Special Lenses

Succeeding the Fish Eye 7.5mm F5.6, a compact lens, and the aspherical lenses, new lenses designed to strengthen the F-1 system are scheduled for release.

B. Utilization of Full Range Aberration Free System

This system was utilized in wide-angle lenses and the FD 55mm F1.2 AL to increase the picture quality for close distance photography.

Low picture quality in close distance photography is conspicuous when using retro-focus type wide-angle lenses and large aperture lenses. When focusing is performed by a completely protruding lens system as in the conventional manner, low picture quality is unavoidable. In order to eliminate this defect, Canon divided the lens system into two parts.

By changing the distance between the lenses when focusing, the aberration arising from the front section is absorbed by the rear section. Thus, as an integrated whole, this mechanism prevents the collapse of the image.

In the case of wide-angle lenses, special care has been taken to prevent deterioration of the image plane curvature. This has resulted in a big difference in performance from conventional wide-angle lenses used in close-up photography.

Deterioration of the image plane curvature has been particularly prevented in the large aperture FD 55mm F1.2 AL lens. Therefore, focusing errors during close distance photography have been eliminated and excellent focusing is available in close-up photography with full aperture opening. This means that the special features of the aspherical lens have been used to their greatest advantage.

As to other lenses which do not incorporate this system, the quality of the lenses was closely checked at the designing stage so that it would not deteriorate during close distance photography. Consequently, the FD group of lenses is guaranteed for high picture at all photographing distances.

FD 17mm F4 Full Range Aberration Free System

At Infinity Position

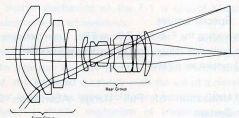

At Closest Distance

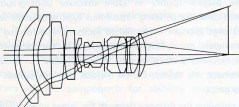

FD 55mm F1.2 AL Full Range Aberration Free System

At Infinity Position

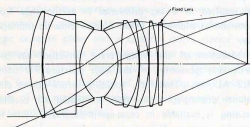

At Closest Distance

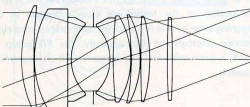

C. Super Spectra Coating

In order to obtain the highest fidelity color reproduction in color photography, Canon lenses are treated with Canon's unique spectra hard coating. This has won world-wide acclaim for Canon lenses. Canon has now developed a new, more sophisticated multilayer coating which greatly increases the performance of the lens. This is called the Super Spectra Coating, and will be applied to lenses according to the purposes for which the lenses are to be used.

The ordinary single-layer coating is not effective as a reflection preventive at all wavelengths. Furthermore, nearly 20 percent of the reflection remains. Canon's Super Spectra Coating increases the effectiveness of reflection prevention throughout the entire range of visible light with its multilayer film of special material and construction. Residual reflection is only a small 0.3 percent.

When a lens is treated with this coating, its light transmission increases, its ghost formation decreases, it gives higher performance during against-the-light photography, and provides high contrast pictures.

Interchangeable Lenses

1) Canon Lens FD 17mm F4

Among the interchangeable lenses with long optical back focal distance for single-lens reflex camera use, this lens has no distortion. As a super-wide-angle lens for normal delineation, it has the world's shortest focal length.

Generally, retro-focus type lenses have the shortcoming of inferior picture quality at close distance photography. This lens, however, changes its air distance of the lens system of close distance photography and prevents aberration breakdowns between infinity and close distance. It incorporates a full range aberration free system that maintains high performance.

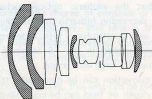

2) Canon Lens FD 24mm F2.8

This is a high-performance retro-focus type lens that has a very fast f/number for a super-wide-angle lens. It incorporates a full range aberration free system.

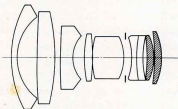

3) Canon Lens FD 35mm F2

This lens makes possible extremely plane images of high contrast and little hollow. As in the case of super-wide lenses, Canon's independently developed mechanism has solved the aberration deterioration at close distance photography. It also assures extremely its resolving power at the photography distance of 30 centimeters.

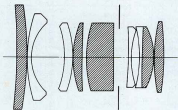

4) Canon Lens FD 50mm F1.4

This lens uses the optical system of the world-renowned FL 50mm F1.4 standard lens.

Its high resolving power and high contrast delineation power are outstanding. It has been three years since it was first marketed, but its performance is still reputed to be very high despite the advances made during this time in optical designing techniques.

The same high reputation is certain for this standard lens for the F-1 use, too, because of Canon's stabilized production techniques.

5) Canon Lens FD 55mm F1.2

This lens, similar to but more advanced than the FD 50mm F1.4 boasts the fastest speed among the series of FD lenses. Its performance has been demonstrated

by the FL lens. Despite its large aperture, it is highly reputed for its high contrast during full aperture opening and for high resolving power.

This lens, like the FD 50mm F1.4, was added to the FD series after a scrupulous recheck of its optical design.

6) Canon Lens FD 135mm F2.5

This lens was made as a result of improving the optical system of the FL 135mm F2.5 lens, a highly regarded lens in the FL series. It possesses the fastest f/number among the FD telephoto lenses. Its focal length makes this lens very useful over a wide range.

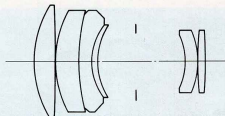

7) Canon Lens FD 200mm F4

This lens, which is an improved version of the conventional FL 200mm F3.5 lens that enjoyed an excellent reputation, is quite superior to its FL counterpart.

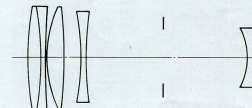

8) Canon Lens FD 300mm F5.6

This lens was developed for the purpose of turning a long focal length lens of 300mm into a high performance, compact lens which would be most convenient and advantageous for telephotography. It is a lens that is certain to fulfill expectations because Canon succeeded in making it compact without the use of the costly and special material called artificial fluoride.

The telephoto ratio of this lens was shortened to 0.72. At the same time, an almost perfect aberration correction was performed on this lens. For these

reasons, sharp delineations of high contrast and high resolving power are obtainable.

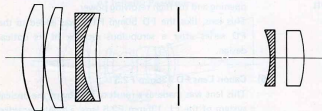

Canon Quality Coatings ensure 91% transmission
 High-Speed Mirror Drive and Maximum Flexibility



Table of Interchangeable Lenses for Canon F-1

Lens	Type	Angle of View	Aperture System	Manually Operated Aperture	Lens Construction	Minimum Aperture
Fish Eye 7.5mm F4.6	Special	180°	Manual	Possible	8-11	22
FD 17mm F4	Super wide angle	104°	Automatic	Possible	9-11	22
FD 24mm F2.8	Super wide angle	53°	Automatic	Possible	2- 9	16
FD 28mm F3.5	Super wide angle	79°	Automatic	Possible	7- 7	16
FD 35mm F3.5	Wide angle	64°	Automatic	Possible	6- 6	16
**TL 35mm F2.8 AL	Wide angle (Tilt & Shift)	79° 42.6'	Manual	Possible	6-10	22
**FD 35mm F2.8	Wide angle	62°	Automatic	Possible	8- 9	16
TL 50mm F3.5	Macro	46°	Automatic	Possible	3- 4	22
**FD 50mm F1.8	Standard	46°	Automatic	Possible	4- 6	16
**FD 50mm F1.4	Standard	46°	Automatic	Possible	3- 4	22
FD 55mm F1.2	Standard	43°	Automatic	Possible	5- 7	16
FD 55mm F1.2 AL	Standard	44°	Automatic	Possible	6- 8	16
FD 85mm F1.8	Long focus	29°	Automatic	Possible	4- 5	16
FD 100mm F2.8	Telephoto	24°	Automatic	Possible	5- 5	22
FD 135mm F3.5	Telephoto	18°	Automatic	Possible	11- 4	22
FD 135mm F2.5	Telephoto	18°	Automatic	Possible	4- 6	22
FD 200mm F4	Telephoto	12°	Automatic	Possible	11- 6	22
FD 300mm F5.6	Long telephoto	8.3°	Automatic	Possible	5- 6	22
FD 55-135mm F3.5	Zoom	43-18°	Automatic	Possible	10-13	22
FD 100-200mm F5.6	Zoom	24-12°	Automatic	Possible	5- 6	22
FL 85-300mm F5	Zoom	29- 8°	Automatic	Possible	9-15	22
****FL 400mm F5.6	Long telephoto	6.2°	Automatic	Possible	5- 7	32
****FL 600mm F5.6	Long telephoto	4.1°	Automatic	Possible	4- 5	32
****FL 800mm F8	Long telephoto	3.1°	Automatic	Possible	5- 7	32
****FL 1200mm F11	Long telephoto	2.1°	Manual	Possible	4- 6	64

* Perspective Adjustment Lens

** Equipped with a coupling pin to CAT SYSTEM.

*** Front component interchangeable type.

**** Focusing adapter used.

***** 1 component, 2-element, FL automatic diaphragm, with A-M ring.

***** Filter is of insertion type with holder.

Number of elements in chart are totals.

Distance Scale	Attachment		Hood	Coating	Case	Length (mm)	Weight (g)	(lb.-oz.)			
	in meter	in feet							Filter	Cap	
—	—	—	Built-in	Exclusive	—	Spectra	Exclusive	53	380	13 1/4	
—	—	—	Built-in	Exclusive	—	Spectra	Exclusive	56	490	1- 1 1/4	
3- 0.25	10- 0.9	72	75	W 558	—	Spectra	C	57.5	410	1- 1/8	
3- 0.4	10- 1.5	55	C 55	W 558	—	Spectra	C	43.0	290	8 1/4	
3- 0.4	10- 1.5	55	C 55	W 55A	—	Spectra	C	44.0	325	11 1/4	
3- 0.3	10- 1	58	C 58	Exclusive	—	Spectra	Exclusive	72	—	—	
3- 0.3	10- 1	55	C 55	W 55A	—	Spectra	C	60	380	13 1/4	
5- 0.24	20- 3.2	—	—	—	—	Spectra	C	49	400	14	
10- 0.6	30- 2	55	C 55	5.55	—	Spectra	C	42.0	305	10 1/4	
10- 0.45	30- 1.5	55	C 55	5.55	—	Spectra	C	49	400	14	
10- 0.6	30- 2	58	C 58	5.58	—	Super Spectra	I	52.5	560	1- 3 1/4	
10- 0.6	30- 2	58	C 58	5.58	—	Super Spectra	I	55	630	1- 6 1/4	
20- 1	60- 3.5	—	—	—	—	Spectra	—	—	—	—	
10- 1	30- 3.5	55	C 55	T 55	—	Spectra	D	57.0	430	1 1/4	
30- 1.5	100- 5	55	C 55	T 55	—	Spectra	E	63.0	480	1- 4 1/4	
30- 1.5	100- 5	58	C 58	—	—	Spectra	E	91	680	1- 8	
30- 2.5	100- 8	55	C 55	—	—	Spectra	J	113	730	1- 9 1/4	
50- 4	200-13	58	C 58	—	—	Built-in	Spectra	Exclusive	173	1190	2-10
30- 1.7	100- 6	58	C 58	—	—	Spectra	—	—	—	—	
30- 2.5	100- 8	55	C 55	—	—	Built-in	Spectra	Exclusive	173.0	820	2-13
50- 4.5	100-12	72	75	—	—	Built-in	Spectra	Exclusive	273.5	1840	4- 1
50-10	—	48	82	Exclusive 82	—	Spectra	Exclusive	338	—	—	
50-10	—	48	114	Built-in	—	Spectra	Exclusive	448	—	—	
50-17	—	48	114	Built-in	—	Spectra	Exclusive	508	—	—	
—	—	48	114	Built-in	—	Spectra	Exclusive	748	—	—	

Booster T Finder with Electronic Timer-Exposure Device for Insufficient Light Volume

The Booster T Finder, one of the most unique accessories of Canon F-1, is a finder attachment with a super-sensitive meter and an exposure timer, and is interchangeable with the pentaprism section of the F-1.

This booster is used in the most significant way on a single-lens reflex camera. The Booster T Finder is an electronic device which determines exposures with ease and which also supplies the proper exposure with the built-in timer during photomicrography, macrophotography, indoor photography and when shooting night scenes under dim lighting conditions.

Full Aperture Metering EE Device - Servo EE Finder

This is an EE functioning electronic device which presets the proper f/stop, with the aperture at full opening, by motor drive after coupling with the full aperture metering mechanism of the F-1.

It is strongly vibration- and shock-resistant compared with a galvanometer. The proper f/stop is readable in the viewfinder, and differences in full aperture openings can be corrected from the outside.

Average metering is adopted for the metering system because of the EE. However, as the center section can be predominantly metered, a most satisfactory exposure can be obtained when shooting scenery that includes the sky. Unmanned continuous shooting is possible with EE through the combined use of the Motor Drive Unit. This has opened up a remarkable photographic field in observation and experiment recording.

Canon Motor Drive Unit

The Canon Motor Drive Unit with its unique functions was developed by the adoption of electronics techniques and in close relation with other accessories for substantial expansion of the F-1 system.

As a result, Canon has completely met strong customer demand, not with an exclusive apparatus or one that is attached through improved adjustments, but with a completely interchangeable device that can be used on any F-1 and in combination with the Film Chamber 250 and still retain its high accuracy. It has the following outstanding

features.

- It can be purchased and used as the demand arises.
- It is attachable to the bottom section of the F-1 and can be used for continuous shooting up to 36 exposures.
- Single-frame exposures and high-speed photography at three exposures per second.
- Built-in timer that can be set at seven intervals up to 60 seconds.
- Remote controlled photography is possible.
- Unmanned photography and automatic stopping after completion of shooting are possible with the combined use of the Servo EE Finder.

Canon Film Chamber 250

The Canon Film Chamber 250 was developed simultaneously with the Motor Drive Unit in order to substantiate its continuous shooting functions. It is a long-length roll film magazine attachable exclusively to the F-1. It can be used for any number of exposures less than 250. Shooting is powered by the Motor Drive Unit, and shooting speeds can be set by a timer at seven stages from three exposures per second up to one exposure per minute. Single-frame exposures are also possible.

Electronic Film Drive and Unmanned Photography

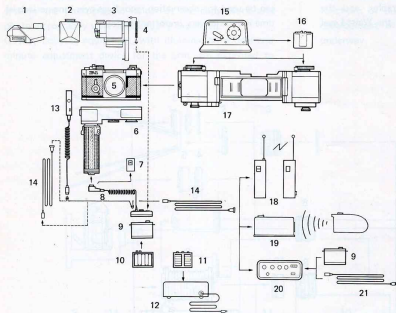

1. Speed Finder
2. Eye-Level Finder
3. Servo EE Finder
4. Cord 12 V 2E.
5. F-1 Body
6. Motor Drive Unit
7. Battery Checker
8. Battery Connector MD.
9. Battery Case
10. Battery Magazine 15 V
11. NiCd 500 FZ
12. NiCd Charger 500 FZ
13. Remote Switch MD.
14. Extension Cord MD.
15. Film Loader 250
16. Film Magazine 250
17. Film Chamber 250
18. Wireless Remote Control Unit
19. Ultrasonic Remote Control Unit
20. Timer
21. AC Cord



Close-Up Photography System

All system accessories for the Canon FT and Pellix can be used. Close-up lenses and intermediate tubes for close-up photography, bellows for macrophotography, and the Booster T Finder, the Speed Finder, and the Waist-Level

Viewer have all greatly expanded the photographic capacity in this field. Moreover, the fact that the motor drive system can be used for observation recordings over long periods of time is another very important factor.

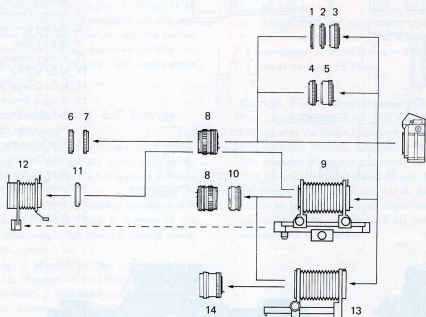

1. Extension Tube M5
2. Extension Tube M10
3. Extension Tube M20
4. Extension Tube FL15
5. Extension Tube FL25
6. Close-up Lens 450
7. Close-up Lens 240
8. Lens
9. Bellows FL
10. Macrophoto Coupler FL
11. Attachment Ring
12. Slide Duplicator FL
13. Bellows M
14. Macro Lens

Copy Work and Photomicrography System

With the use of conventional devices and the F-1 Finder system, the photographic ranges of the copy work and photomicrography were substantially expanded.

Quality copying equipment, with illumination source and minute adjustment device for the arm, are expected to

appear on the market. This means that the superior functions of the F-1 can be put to full use. Ambitious development of special photographic apparatus is also underway.

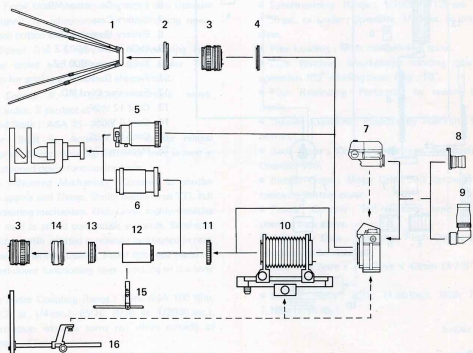

1. Handy Stand F
2. F-Ring
3. Lens
4. Extension Tube M5
5. Photomicro Unit F
6. Microphoto Hood
7. Booster T Finder
8. Magnifier
9. Angle Finder B
10. Bellows FL
11. Lens Mount Converter A
12. Extension Tube
13. Mount Converter B
14. Macrophoto Coupler FL
15. Macrophoto Strut
16. Copy Stand 3F

Power System

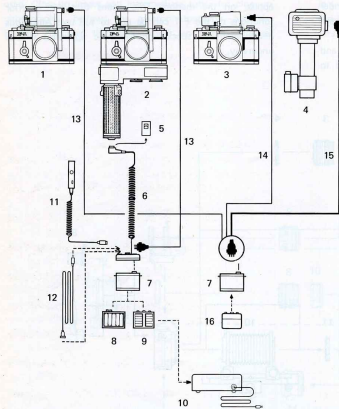

1. F-1 with Servo EE Finder
2. F-1 with Servo EE Finder and Motor Drive Unit
3. F-1 with Booster T Finder
4. Speedlite 500A
5. Battery Checker
6. Battery Connector MD.
7. Battery Case
8. Battery Magazine 15 V
9. NiCd Battery 500 FZ
10. NiCd Charger 500 FZ
11. Remote Switch MD.
12. Extension Cord MD.
13. Cord 12 V 2E.
14. Cord 6 V 2B.
15. Cord 12 V 3S.
16. Magazine 12 V

Technical Data

- Type : 35mm single-lens reflex camera with focal plane shutter. Picture size ; 24 x 36mm.
- Lens : Interchangeable lens group of FD series with full aperture signal lever.
- Standard Lens : Canon FD 55mm F1.2, FD 50mm F1.4, FD 50mm F1.8.
- Viewfinder : Removable pentagonal prism finder. Interchangeable with Servo EE Finder, Booster T Finder, Speed Finder, Waist-Level Finder.
- Finder Attachments : Angle Finder B, Magnifier, Diprict Adjustment Lens, Eyecup.
- Focusing Screen : Using fresnel lens, standard focusing glass with microprism screen rangefinder and three other

interchangeable kinds. With metering beam-splitting condenser.

- Field-of-View : 97% of actual picture area. 0.77 x with standard 50mm lens at infinity.
- Finder Information : Meter needle and metering needle, improper exposure warning red mark, fixed dot for stopped-down metering use and battery check mark, shutter speed scale, out of meter functioning range warning signal.
- Diprict Adjustment Lenses : Standard -1.2 diopter (R 0). Interchangeable with R + 3, R + 2, R + 1, R - 1, R - 2, R - 3, and R - 4.
- Mirror : Quick return mirror with shock-absorbing

mechanism. Mirror can be fixed in upper position. Aperture is manually operated when mirror is fixed in upper position.

■ Lens Mount : Bayonet type FD mount. FL and R series of lenses mountable.

■ Function : FD lenses ; full aperture metering, coupled with automatic diaphragm. FL lenses ; stopped-down metering, coupled with automatic diaphragm. R lenses ; stopped-down metering, manually operated diaphragm.

■ Shutter : Focal plane shutter using super thin titanium screen. Designed for elimination of functioning noise. Shutter release button can be locked.

■ Shutter Speed Dial : Single shaft non-revolving type with shutter scales and ASA film speed scales. Two coupling pins for setting attachments are provided.

■ Shutter Speeds : B, 1-1/2000. Multiple series. Equivalental index. X contact at 60.

■ Film Speed Scale : ASA 25-2000.

■ Self-Timer : Built in. Activate with shutter release button. Approx. 10 sec. time lag. Selftimer lever is used in common as stopped-down functioning lever.

■ Exposure Adjusting Mechanism : Coupled to shutter speeds, film speeds and f/stop. Match needle type TTL full aperture measuring mechanism. Wide range, highly sensitive special CdS used as photo conductive elements. Semi-spot metering system with splitted condenser positioned in rear. Stopped-down metering possible. Fixed dot type metering using stopped-down functioning lever. Locking of the lever possible.

■ Exposure Meter Coupling Range : With ASA 100 film, EV2.5 (f/1.2 at 1/4 sec.)-EV19 (f/16 at 1/2000 sec.). Meter information window turns red when outside of coupling range.

■ Meter Battery : One 1.3v M20 (#625) mercury battery used.

■ Battery Checker : Built in. Check at ASA 100, shutter speed at 1/2000 sec.

■ TTL Full Aperture Metering System EE : Uses exclusive Servo EE Finder and Battery Case in combination. Full aperture metering with FD lens. Shutter priority type EE. Functioning range ; with ASA 100 film EV2.5 (f/1.2 at 1/4 sec.)-EV19 (f/16 at 1/2000 sec.).

■ Ultra-low Illumination Metering : Metering possible between ASA 100 film EV1.5 (f/1.2 at 1/2 sec.) and EV3.5 (f/1.2 at 15 sec.) with use of exclusive Booster T Finder.

■ Synchronized Flash : FP and X contact. Automatic time lag adjusting type.

■ Flash Socket : On front side of body. Two contacts on film rewind knob for flash circuit for directly connected adapter, and meter circuit.

■ Canon Auto Tuning (CAT) System : Diaphragm control by recharge completion signal and rangefinder signal. Proper aperture is established by the meter matching needle system through the connection of the Speedlite 500A Flash Coupler, Flash Adapter and prescribed FD 50mm F1.4, FD 50mm F1.8, or FD 35mm F2 lens.

■ Synchronizing Range : 1/2000-1/125 sec. ; FP class. 1/60 sec. or under ; Speedlite, 1/30 sec. or under ; M, MF class.

■ Film Loading : With multislit film spool.

■ Film Winding : Short-stroke winding possible. Single operation 180° winding lever. Play ; 10°.

■ Film Rewinding : Performed by rewind button and crank.

■ Double Exposure : Possible by operating film rewind button.

■ Back Cover : Crank pull-up type. Removable for Film Chamber 250.

■ Bottom Cover : Motor Drive Unit can be attached after removing bottom cover.

■ Frame Counter : Self-resetting type activated by opening back cover.

■ Accessory Shoe : Exclusive. Flash Couple D and other couplers can be attached.

■ Size : 98.7mm x 146.7mm x 43mm (3-7/8" x 5-3/4" x 1-11/16").

■ Weight : Body ; 820g (1.80 lbs.). With F1.4 Lens ; 1,180g (2.60 lbs.).

Subject to alterations.